

Bohle Liftmaster B1

Innovative handling aid



For structural components up to 180 kg



Bohle Liftmaster B1

The tendency towards increasingly larger glass constructions in architecture and the growing use of 2-gap insulating glass pose new challenges for glass processors and assemblers: Elements which could previously be moved by two people have now become so heavy that they can hardly be transported manually on site or within company premises any longer. With Liftmaster B1, Bohle has developed an innovative handling and mounting aid which enables moving heavy elements of up to 180 kg, such as glass panes, window elements or metal and stone sheets easily and safely – by only one person.

- Power / energy independent dual circuit vacuum system as per DIN EN 13155
- Ideal for transport within company premises and on construction sites
- Easy and secure handling of structural components of up to 180 kg
- Easy assembly of structural components
- Can be disassembled easily, fits in any estate car
- Stable construction
- Rack can be rotated and tilted
- Very compact and manoeuvrable
- Fits through standard doors
- Handle is height adjustable
- 180 kg Load capacity

Includes vacuum lifter

BO B18DM4 can be rotated by 360° · can be removed very easily and used separately together with a crane · has a dual circuit vacuum system with 4 suction pads · is very flat and compact · is equipped with a vacuum indicator for monitoring the vacuum · the vacuum is generated via a hand pump, therefore ready for use at all times (no previous charging of batteries required) · Weight of the vacuum lifter approx. 22 kg

| TECHNICAL DATA | ART. NO. |
|----------------|--|
| | BO 88.01 |
| Load capacity | 180 kg |
| Length | 1200 mm |
| Width | 790 mm ((with extended axles for widening the gauge 1080 mm) |
| Height | 1980 mm |

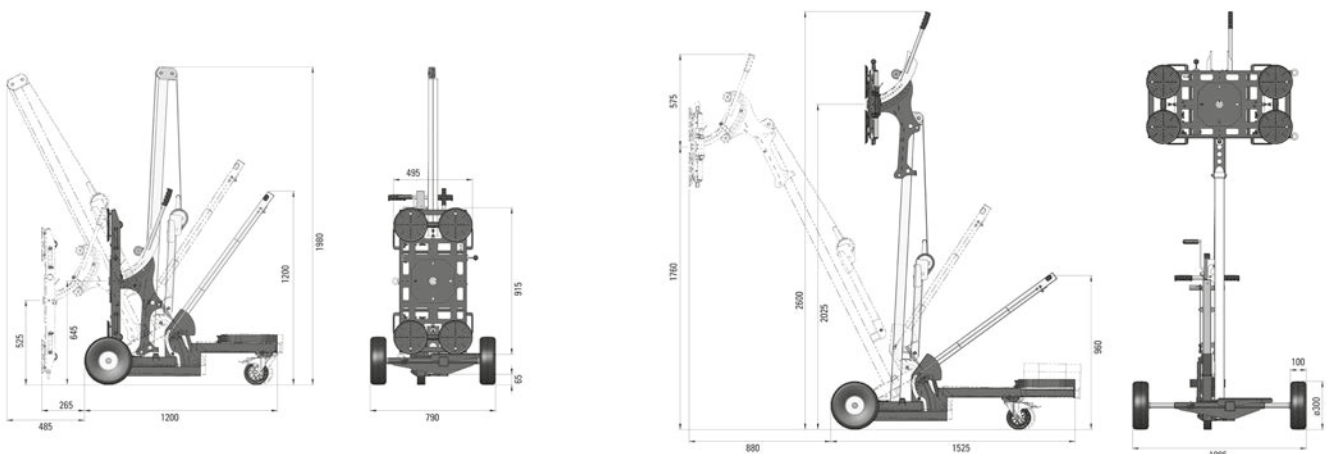



Additional counterweight, 25 kg

ART. NO.
BO 88.025



Arm with tilt and swivel function for B18DM4 lifting system

ART. NO.
BO 88.026



Protective cover for suction pads, ø 220 mm

ART. NO.
SP BT1800

- Vacuum generation with manual pump, therefore always ready for use (independent of power supply, no charging of batteries required)
- Dual circuit vacuum system with 4 suction pads
- For use at the construction site or in the workshop
- Very flat and compact
- Weight only 31 kg
- Load capacity 180 kg
- Vacuum indicator for monitoring the vacuum
- Can be rotated by 360°/ tilted by 90°

Product highlights



The manual lifting device can do without an electric pump and is therefore very versatile in use. A dual circuit vacuum system, reserve tanks, vacuum display and an additional visual vacuum indicator ensure high levels of safety. The manual lifting device stands out due to its very compact construction and low weight.

Load capacity max.

180 kg

| TECHNICAL DATA | BO B180DM4 |
|------------------------------------|---|
| Suction pad | Four rubber suction pads, Ø 210 mm |
| Load capacity | 180 kg |
| Rotating range | Manual, 360°, with four locking positions |
| Swivel range | Manual, 90°, can be locked in vertical pos. |
| Vacuum pump | Manual |
| Vacuum indication via vacuum gauge | 2 |
| Maximum operating altitude | 1,680 m above sea level |
| Working temperatures | 10° - +40° C |

